

VENT-O-MAT AIR VALVES ARE DESIGNED TO FULFILL FOUR FUNCTIONS NAMELY:
 LARGE VOLUME AIR DISCHARGE - PIPELINE FILLING
 PRESSURIZED AIR DISCHARGE - PIPELINE OPERATING
 AIR INTAKE (VACUUM BREAKING) PIPELINE DRAINING
 SURGE PROTECTION - RAPID FILLING OR COLUMN SEPARATION

© Copyright D.F.C. (Pty) Ltd.

D.F.C. WATER
 32 Lincoln Road, Benoni South
 P.O. BOX 5064, Benoni South,
 1502
 Tel: (011) 748 0200
 Fax: (011) 421 2749

TITLE:
DN80 (3") - PN25 VENT-O-MAT
RBX SERIES DBL ACTING AIR VALVE

DRAWN: D.D. DATE: 30/09/2010 CHECKED: L.H. DATE: 30/09/2010

SCALE: 1:3 A3

PROJECTION: 1 ST. ANGLE 3 RD. ANGLE

REV.	DATE	SIGN	DESCRIPTION

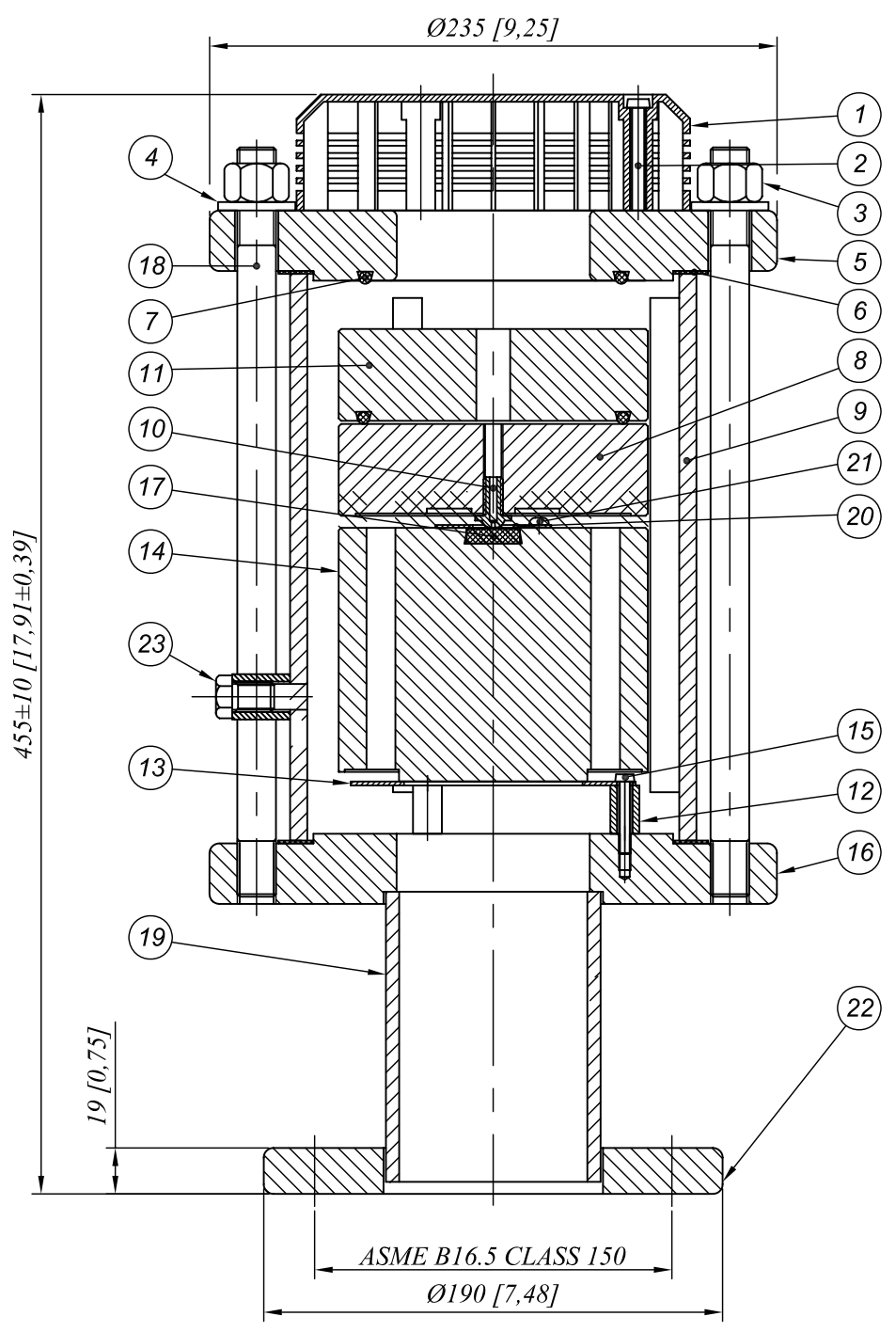

NOTE:
 1. DIMENSIONS IN BRACKETS ARE IN INCHES
 2. OPERATING PRESSURE MIN. 7PSI TO MAX 362 PSI

DN mm (in)	MODEL No.	WEIGHT kg (lbs)		
80(3")	080 RBX 2531	31 (68)		
ITEM	QTY	DESCRIPTION	MATERIAL	
1	1	080 RBX TOP COVER	ABS POLYLAC PA 737	
2	3	TOP COVER SCREWS	S/STEEL 304	
3	8	M16 HEX NUT	S/STEEL 304	
4	8	M16 WASHER	S/STEEL 304	
5	1	080 RBX UPPER FLANGE	M/STEEL F.B.E.	
6	2	100 RBX BARREL SEAL DWAF	TEADIT NA 1002	
7	2	100 x 5 O-RING SEAL	E.P.D.M.	
8	1	080 RBX UPPER FLOAT	WHITE HDPE	
9	1	080 RBX BARREL - 64 BAR	S/STEEL 304	
10	1	080 RBX NOZZLE	S/STEEL 316	
11	1	080 RBX ANTI SHOCK FLOAT	WHITE HDPE	
12	3	080 RBX BAFFLE SPACER	ABS POLYLAC PA 737	
13	1	080 RBX BAFFLE PLATE	S/STEEL 316	
14	1	080 RBX LOWER FLOAT - 64 BAR	WHITE HDPE	
15	3	BAFFLE PLATE SCREWS	S/STEEL 316	
16	1	080 RBX LOWER FLANGE	M/STEEL F.B.E.	
17	1	25 RBX NOZZLE SEAT	E.P.D.M.	
18	8	100 RBX TIE RODS	S/STEEL 304	
19	1	SPOOLE PIECE	M/STEEL F.B.E.	
20	1	NOZZLE SEAT RETAINER PLATE	S/STEEL 316	
21	3	NOZZLE SEAT RETAINER SCREWS	S/STEEL 316	
22	1	MATING FLANGE	M/STEEL F.B.E.	
23	1	½" NPT SOCKET WITH PLUG	S/STEEL 304	

TYPE: 080RBX2531
 080RBX25IS4T1Y
 DRG No./ GA REF No.
 SHEET: 1 OF 1