

VENT-O-MAT AIR VALVES ARE DESIGNED TO FULFILL FOUR FUNCTIONS NAMELY:
 LARGE VOLUME AIR DISCHARGE - PIPELINE FILLING
 PRESSURIZED AIR DISCHARGE - PIPELINE OPERATING
 AIR INTAKE (VACUUM BREAKING) PIPELINE DRAINING
 SURGE PROTECTION - RAPID FILLING OR COLUMN SEPARATION

© Copyright D.F.C. (Pty) Ltd.

D.F.C. WATER

32 Lincoln Road, Benoni South
 P.O. BOX 5064, Benoni South,
 1502
 Tel: (011) 748 0200
 Fax: (011) 421 2749

TITLE:
DN50 (2") - PN16 VENT-O-MAT
RBX SERIES DBL ACTING AIR VALVE

DRAWN: D.D. DATE: 30/09/2010 CHECKED: L.H. DATE: 30/09/2010

SCALE: 1:2.5 A3
 PROJECTION: 1 ST. ANGLE 3 RD. ANGLE

REV.	DATE	SIGN	DESCRIPTION

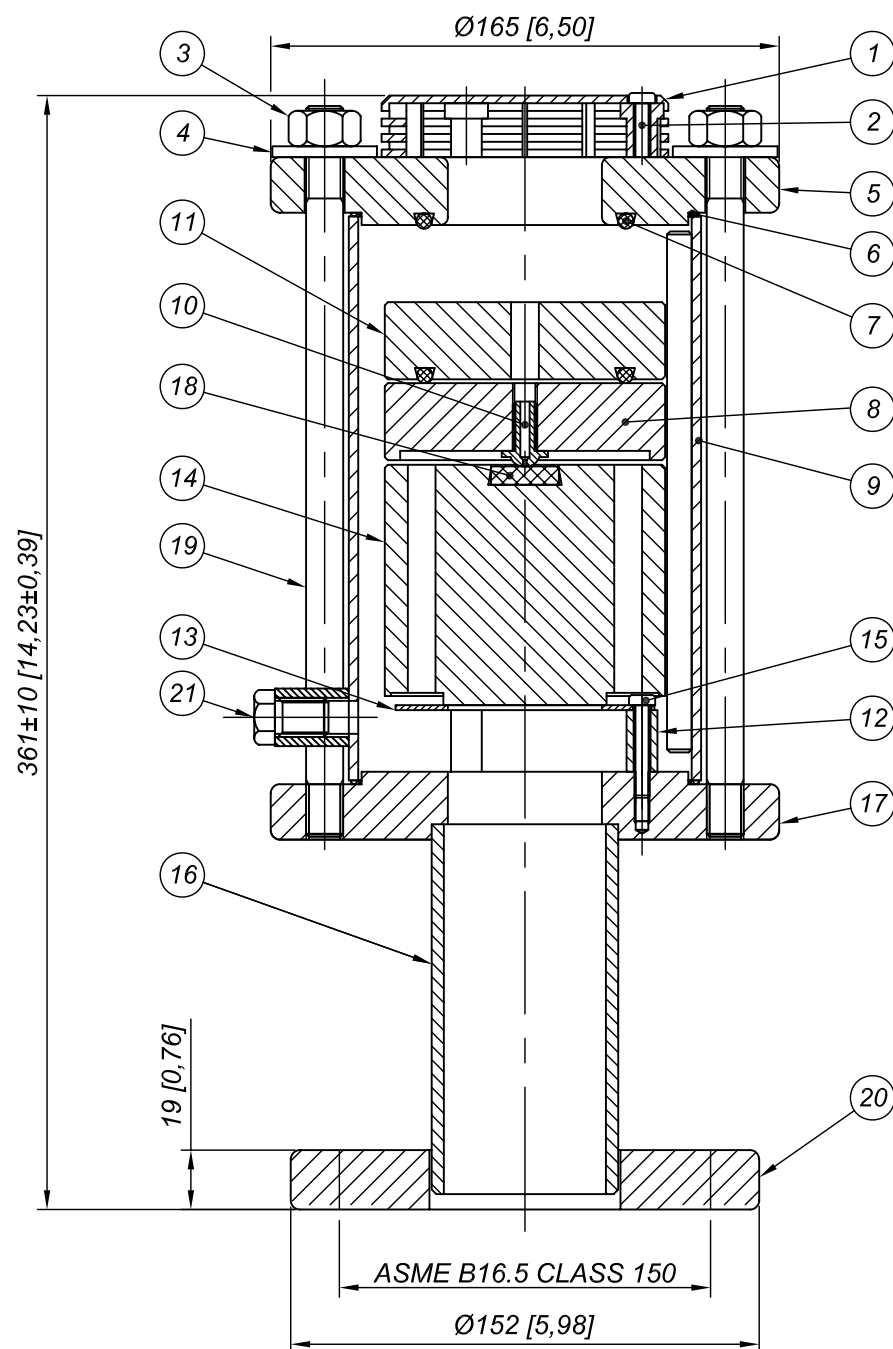

NOTE:
 1. DIMENSIONS IN BRACKETS ARE IN INCHES
 2. OPERATING PRESSURE MIN. 7PSI TO MAX 232 PSI

DN mm (in)	MODEL No.	WEIGHT ±kg (lbs)		
50(2")	050 RBX 1631	11 (24)	TYPE: 050RBX1631	
ITEM	QTY	DESCRIPTION	MATERIAL	
1	1	50 RBX TOP COVER	ABS POLYLAC PA737	
2	3	TOP COVER SCREWS	S/STEEL 316	
3	4	M12 HEX NUT	S/STEEL 304	
4	4	M12 WASHER	S/STEEL 304	
5	1	50 RBX UPPER FLANGE	M/STEEL F.B.E.	
6	2	50 RBX BARREL SEAL	TEADIT NA 1002	
7	2	60 x 5 O-RING SEAL	E.P.D.M.	
8	1	50 RBX UPPER FLOAT	WHITE HDPE	
9	1	50 RBX BARREL	S/STEEL 304	
10	1	025 RBX NOZZLE	S/STEEL 316	
11	1	50 RBX ANTI SHOCK FLOAT	WHITE HDPE	
12	3	50 RBX BAFFLE SPACER	ABS POLYLAC PA 737	
13	1	50 RBX BAFFLE PLATE	S/STEEL 316	
14	1	50 RBX LOWER FLOAT - 25 BAR	WHITE HDPE	
15	3	BAFFLE PLATE SCREWS	S/STEEL 316	
16	1	50 RBX SPOOLE PIECE	M/STEEL F.B.E.	
17	1	50 RBX LOWER FLANGE	M/STEEL F.B.E.	
18	1	25 RBX NOZZLE SEAT	E.P.D.M.	
19	4	50 RBX TIE RODS	S/STEEL 304	
20	1	MATING FLANGE	M/STEEL F.B.E.	
21	1	½" NPT SOCKET WITH PLUG	S/STEEL 304	

TYPE: 050RBX1631
 050RBX161S4T1Y
 DRG No./ GA REF No.
 SHEET: 1 OF 1